

STUART

Installation, Operation & Maintenance Instructions

Please leave this instruction booklet with the owner as it contains important guarantee, maintenance and safety information



Read this manual carefully before commencing installation.

This manual covers the following products.

Jet 55-45
Pt. No. 46587

Jet 80-45
Pt. No. 46588

50 Hz



PRODUCT DESCRIPTION

Electric motor driven, close coupled, single stage, end suction configuration and of centrifugal design with integral Jet injector.

APPLICATION

The Jet Pump range is designed to pump clean fresh water.

The pumps can be used for applications such as water transfer and distribution, pressure boosting and irrigation. The pump can be used for portable applications and is also suitable for self-priming (after initial priming) installations using the optional suction hose/footvalve assembly.

STORAGE

If this product is not to be installed immediately on receipt, ensure that it is stored in a dry, frost and vibration free location in its original packaging.

CONTENTS

	Page
Checklist5
Important Facts – Read before commencing installation6
Location7
Electrical Installation10
Commissioning12
Maintenance14
Technical Specification15
Trouble Shooting16
Guarantee17

WARNINGS:



- This pump set must not be used for any other application without the written consent of Stuart Turner Limited and in particular, must not be connected directly to the mains water supply.
- This appliance can be used by children aged from 8 years and above and persons with reduced physical, sensory or mental capabilities or lack of experience and knowledge if they have been given supervision or instruction concerning use of the appliance in a safe way and understand the hazards involved.
- Children shall not play with the appliance.
- Cleaning and user maintenance shall not be made by children without supervision.
- Maximum head (closed valve) Jet 55-45-45 metres, Jet 80-45-45 metres.
- The motor casing can become very hot under normal operating conditions. Care must be taken to ensure it cannot be touched during operation.
- The electrical installation must be carried out in accordance with the current national electrical regulations.



- The electrical installation must be installed by a qualified person.
- In the interests of electrical safety a 30 mA residual current device (R.C.D. not supplied) should be installed in the supply circuit. This may be part of a consumer unit or a separate unit.
- Before starting work on the electrical supply ensure power supply is isolated.
- DO NOT allow the supply cord to contact hot surfaces, including the motor shell, pump body or pipework. The cord should be safely routed and secured by cable clips.



- **This appliance must be earthed via the supply cord, which must be correctly connected to the earth point located in the terminal box.**
- **The supply cord and internal wiring within the terminal box are routed and secured to ensure compliance with the electrical standard EN 60335-1. It is essential that prior to any disturbance of this internal wiring, all cable routing and securing details are carefully noted to ensure re-assembly to the same factory pattern is always maintained.**
- **If the supply cord is to be changed or is damaged, it must be replaced with a special cord assembly available from Stuart Turner or one of their approved repairers.**

Please read installation details carefully as they are intended to ensure this product provides long, trouble free service. Failure to install the unit in accordance with the installation instructions will lead to invalidation of the warranty.

CHECKLIST

IMPORTANT: With the pump removed from its packaging check for any damage prior to installation. If any damage is found contact Stuart Turner Ltd within 24 hours of receipt.

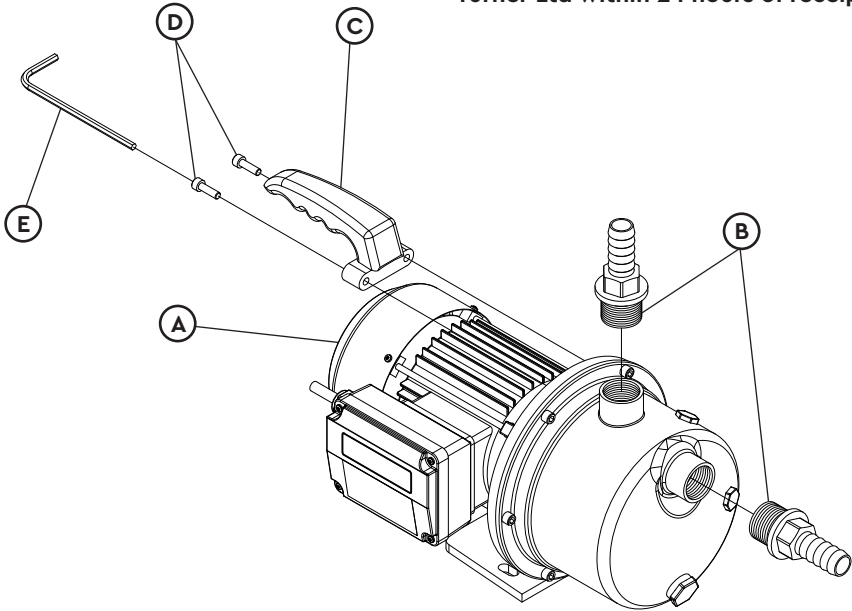

Fig. 1

Item	Description	Qty	Item	Description	Qty
(A)	Pump	1	(D)	Handle screws	2
(B)	19 mm x G 1 Hose union	2	(E)	5 mm Allen key	1
(C)	Handle	1			

Your product may vary slightly from the picture above.

Cont ...

1 IMPORTANT FACTS: READ BEFORE COMMENCING PUMP INSTALLATION

A Water storage capacity.

- 1.11 The cold water storage capacity must be sufficient to meet the flow rates required by the pumped equipment and any other water using fittings and appliances, which may be operated simultaneously.
- 1.12 Ensure the pump is primed as described in the priming section before starting, damage to the shaft seal will result otherwise. See Section 4 – Commissioning.

B Water temperature

The water entering the pump must be controlled as follows:

- 1.13 The maximum allowable water temperature is 35 °C.
- 1.14 The minimum allowable water temperature is 4 °C.

C Pipework – General

- 1.15 **Secure pipework:** Ensure pipework to and from pump is independently supported & clipped to prevent forces being transferred to inlet and outlet branches of pump.
- 1.16 **Flux:** Solder joints must be completed and flux residues removed prior to pump installation (**flux damage will void any warranty**).
- 1.17 **Pipework design:** Care should be taken in the design of pipework runs to minimize the risk of air locks e.g. use drawn bends rather than 90° bends.



- 1.18 **DO NOT** introduce solder flux to flexible hoses, pumps or pump parts manufactured from plastic.
- 1.19 **DO NOT** allow contact with oil or cellulose based paints, paint thinners or strippers, acid based descalents or aggressive cleaning agents.
- 1.20 **DO NOT** install a non-return valve, or devices which contain non-return valves, in the suction (inlet) pipework to the pump. The pump must be free to vent to the supply tank at all times. Exceptions can be made in the case of suction lift installations when a footvalve is required.
- 1.21 **DO NOT** connect this pump to the mains water supply.

D Plumbing Installation Regulations

- 1.22 The plumbing installation must comply with the current water and building regulations.
- 1.23 The plumbing installation must be installed by a qualified person.

2 LOCATION – GENERAL



- 2.11 **Access:** For emergencies and maintenance the pump must be easily accessible.
- 2.12 **Protection:** The pump must be located in a dry position, frost free and protected from freezing, particularly when installed in a loft (not recommended).
- 2.13 **Ventilation:** Ensure an adequate air flow to cool the pump. Separate the pump from other appliances that generate heat. An 80 mm (3 ") air gap must be maintained around the pump.
- 2.14 **Safety:** The motor casing can become very hot under normal operating conditions. Care must be taken to ensure it cannot be touched during operation.
- 2.15 **Water retention:** Site in a location where in the unlikely event of a water leak, any spillage is contained or routed to avoid electrics or areas sensitive to water damage.
- 2.16 **Static inlet pressure:** Before deciding where to locate the pump check to ensure the static inlet head (Fig. 2) meets the minimum requirement of 1 metre and does not exceed the maximum requirement of 5 metres.
- 2.17 **Ambient temperature:** The pump must be sited in a location where the maximum ambient temperature does not exceed 40 °C.
- 2.18 **Pipework:** For optimum performance pipework 28 mm should be used. 22 mm is acceptable, however, any pipe size reduction will reduce the pumps performance.
- 2.19 **Do not run against a closed valve for periods longer than 5 minutes.**
- 2.20 **Portable:** The pump is suitable for use as a portable unit and is provided with a carrying handle for this purpose.
- 2.21 **Pipe size:** To prevent loss of pressure through pipework, use pipe size to match pump (19 mm internal diameter) whenever possible, minimising 90° bends (sweeping bends).
- 2.22 **Isolating valves:** If permanently installed, isolating valves **MUST** be fitted in suction and delivery pipework to enable easy isolation and access to the pump.
- 2.23 **Inline strainer:** When pump is to be installed in areas where there is risk of debris or scale build up within the system, you **MUST** ensure the inlet pipework is fitted with an inline strainer.

2 LOCATION – PUMP MOUNTED BELOW WATER SOURCE

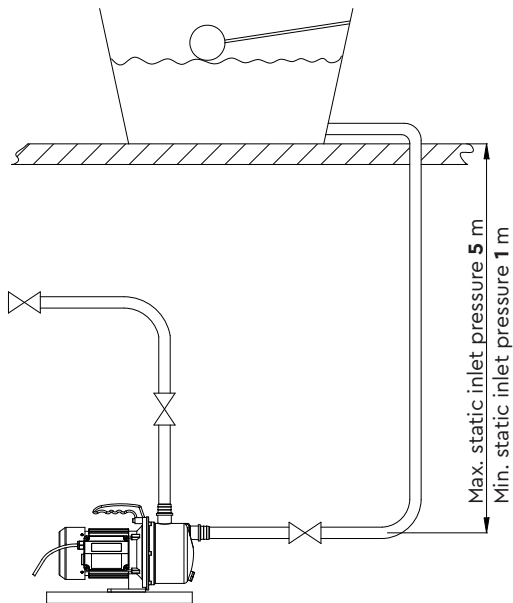

Fig. 2

2.24 **Water supply:** **Must** be made via a tank connector offering a dedicated supply direct to the pump.

2 LOCATION – PUMP MOUNTED ABOVE WATER SOURCE (SUCTION LIFT INSTALLATION)

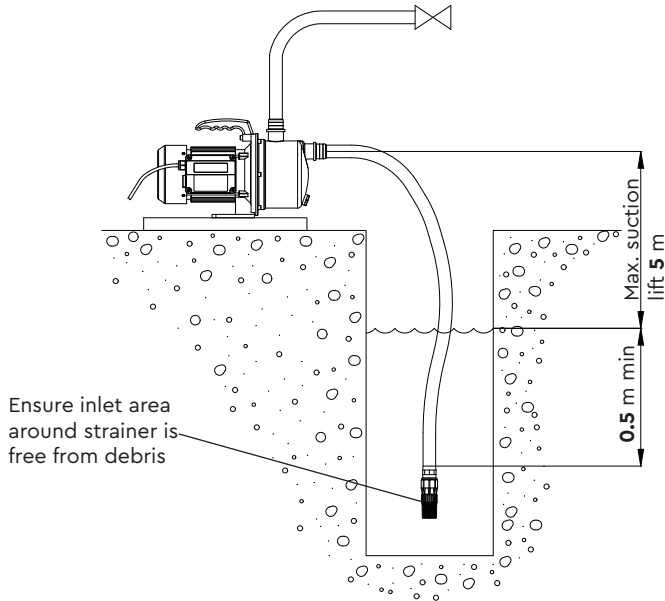

Fig. 3

- 2.25 **Self Priming:** Jet 55–45 and 80–45 pumps are capable of self priming the suction hose assembly, providing a footvalve and strainer (not supplied) is always used for this type of installation. The Jet pump can be used in a suctionlift installation providing the height of lift is no greater than maximum permitted (Fig. 3).
- 2.26 **Footvalve/strainer:** It is important that the optional footvalve and strainer is always used for suction lift installations. This pump is capable of a maximum suction lift of 5 m in this case only, an NRV in the footvalve is permissible (Fig. 3), Stuart Pt. No 26704.
- 2.27 **Suction pipe:** Lay the suction piping over the shortest possible distance and ensure there is a constant rise from the water source to the pump. Any high spots will cause air pockets to form reducing system efficiency. The suction hose must be a minimum of 25 mm to ensure the pump is not starved of water and must be reinforced to prevent it collapsing.
- 2.28 **Connections:** Ensure all joints in suction pipework are completely airtight. Failure to comply will result in loss of prime.
- 2.29 **Position:** The intake of the footvalve/strainer should be positioned so that it cannot be blocked with debris or silt that are frequently found in the bottom of sumps and wells.

3 ELECTRICAL INSTALLATION / EARTHING



- 3.11 **Regulations:** The electrical installation must be carried out in accordance with the current national electrical regulations and installed by a qualified person.
- 3.12 **Safety:** In the interests of electrical safety a 30 mA residual current device (**R.C.D. not supplied**) should be installed in the supply circuit. This may be part of a consumer unit or a separate unit.
- 3.13 Before starting work on the electrical supply ensure power supply is isolated.
- 3.14 **DO NOT** allow the supply cord to contact hot surfaces, including the motor shell, pump body or pipework. The cord should be safely routed and secured by cable clips.
- 3.15 **Earthing:** This appliance must be earthed via the supply cord, which must be correctly connected to the earth point located in the terminal box.
- 3.16 **Electrical Connection:** The pump is provided with a factory fitted supply cord and plug. This must be connected to the mains supply via a 13 Amp double pole switched, socket outlet in compliance with BS 1363-2. The socket outlet should be mounted in an easily accessible position and should be labelled if confusion is possible, to allow easy identification of the pump isolating switch.
- 3.17 **Wiring of connection unit:**



WARNING: A plug with bared flexible cords is hazardous if engaged in a live socket outlet.

The moulded plug fitted to this appliance is not waterproof – keep dry.

The supply cord is factory fitted with a moulded plug incorporating a fuse, the value of which is indicated on the pin face of the plug. Should the fuse need to be replaced, an ASTA approved BS 1362 fuse must be used of the same rating, marked thus, . If the fuse cover is detachable, never use the plug with the cover omitted. If a replacement fuse cover is required, ensure it is of the same colour as that visible on the pin face of the plug (i.e. red or orange).

The wires in the mains lead (supply cord) are coloured in accordance with the following code:

Green and Yellow: Earth

Blue: Neutral

Brown: Live

As the colours of the wires in the mains lead of this appliance may not correspond with the coloured markings identifying the terminals in your connection unit proceed as follows:

- The wire which is coloured green and yellow must be connected to the terminal in the connection unit which is marked with the letter E or by the earth symbol:  or coloured green or green and yellow.
- The wire which is coloured blue must be connected to the terminal which is marked with the letter N or coloured black.
- The wire which is coloured brown must be connected to the terminal which is marked with the letter L or coloured red.

3.18 **Wiring Diagram:**



The supply cord and internal wiring within the terminal box are routed and secured to ensure compliance with the electrical standard EN 60335-1. It is essential that any disturbance of this internal wiring is avoided and the factory routing and securing of all internal wiring is always maintained.

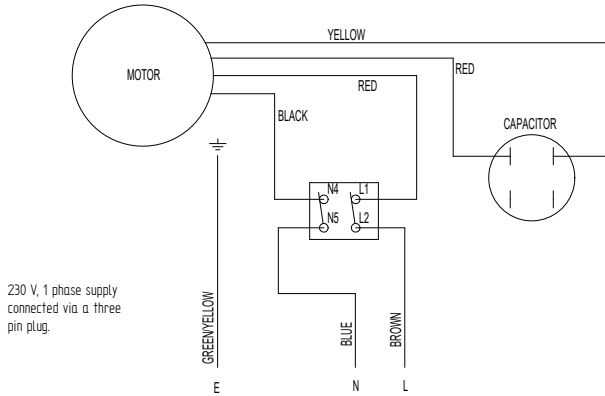

Jet 55-45 and Jet 80-45
Fig. 4

3.19 **Fuse:** The following fuse size should be used with the appropriate pump:

Model	Fuse Size (AMPS)
All Models	13

4 COMMISSIONING



4.11 **System Flushing:** The pipework system should be flushed out prior to the pump being connected to ensure any contaminants/ chemical residues and foreign bodies are removed from elsewhere in the system.

4.12 **Water Supply:** Always ensure that water storage capacity is adequate to meet the demand. Ensure the pump chamber is full of water before starting the pump. Failure to do this could result in seal damage. To ensure dry running does not occur the pump must be primed as described in priming section below. **Do not run pump dry.**

4.13 **Priming:** Prior to switching the pump on and connecting the outlet hoses to the system pipework the pump chamber must be primed. The pump must be primed (filled with water) before starting. Turn on water supply, prime and vent the pump by unscrewing the priming plug (Fig. 5) slowly until all air escapes and water emerges. Re-tighten the plug.

4.14 **Suction lift installation:** Self priming of suction hose.
First ensure both suction and delivery hose connections are airtight. Remove the priming plug (Fig. 5) and slowly fill the pump body with water, whilst allowing the air to escape. Replace the plug.

4.15 **Suction hose:** Ensure the suction hose end is fully submerged in the water source and the delivery hose is open to enable the pump to vent air.

4.16 **Starting The Pump:** Turn on the electrical supply to the pump which will now be operational.

Note: There is an integral on/off switch mounted on the pump (Fig. 5) which must be turned to the on position.

- a) The pump will start and begin to prime the suction pipework.
- b) The priming procedure may need to be repeated if pump does not prime within 5 minutes of starting.

Note: The amount of time required for priming will vary dependent on the height of the suction lift.

- c) Carefully check pump and pipework for leaks whilst pump running and stationary before leaving the installation unattended.



The pump chamber must be full of water at all times. Seal damage will result if the pump runs dry.

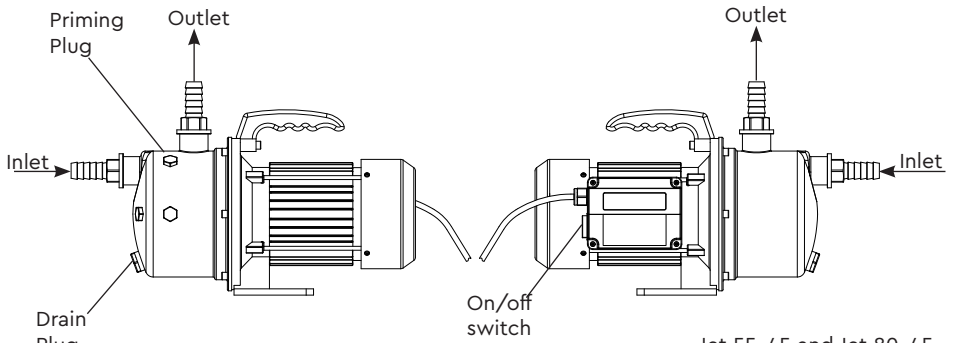

Jet 55-45 and Jet 80-45
Fig. 5

4.17 **For further technical support:** Phone the Stuart Turner TechAssist team on +44 (0) 800 31 969 80. Our staff are trained to help and advise you over the phone.

5 MAINTENANCE

- 5.11 No routine maintenance is required but provision should be made for easy access to the pump to allow for repairs due to normal wear and tear.
- 5.12 Disconnect electrical supply before working on pump.
- 5.13 Turn off water supplies to the pump and release pressure by opening outlets before attempting maintenance.
- 5.14. If the installation is fitted with a footvalve and strainer or inline suction strainer, the strainer must be cleaned as necessary to ensure the pump has unrestricted flow.
- 5.15. After maintenance is completed, refer to commissioning section for instructions on restarting pump.
- 5.16 **Cleaners, Disinfectants and Descalents:**



Acid based descalents and aggressive cleaning agents must not come into contact with the pump. The pump must be removed from the system prior to the use of these products. The system should be flushed to remove all chemicals before the pump is re-connected. If in any doubt as to the suitability of the chemical solutions, please contact our TechAssist helpline on +44 (0) 800 31 969 80.

6 TECHNICAL SPECIFICATION

Pump Model		Jet 55-45 50 Hz 46587	Jet 80-45 50 Hz 46588
General	Guarantee	1 year	
	Approvals	CE	
Features	Pump type	Centrifugal	
	Self priming	✓	✓
	Carry handle	✓	✓
	Integral on/off switch	✓	✓
	Typical noise	68 dB(A)	72 dB(A)
Materials	Pump body	Stainless steel	
	Impeller	Plastic	
	Mechanical seal	EPDM / Carbon / Ceramic	
Performance	Maximum head (closed valve)	4.5 bar / 45 metres	4.5 bar / 45 metres
	Performance @ 9 l/min	3.6 bar / 36 metres	4.1 bar / 41 metres
	Performance @ 50 l/min	0.7 bar / 7 metres	2.6 bar / 26 metres
	Maximum flow	55 l/min	80 l/min
	Minimum static inlet pressure	0.1 bar (1 metre)	
	Maximum static inlet pressure	0.5 bar (5 metres)	
	Maximum working pressure*	500 kPa (5 bar)	
	Maximum ambient air temperature	40 °C	
	Min / Max water temperature	Min 4 °C / Max 35 °C	
	Maximum suction lift**	5 metres	
Connections	Pump connections	G 1 female (inlet), G 1 female (outlet)	
Motor	Type	Induction, auto-reset thermal trip	
	Duty rating	Continuous (S1)	
Electrical	Power supply (Vac/Ph/Hz)	230 V a.c. / 1 / 50 Hz	
	Power consumption - P1	640 Watts	925 Watts
	Current - full load	2.9 Amps	5.2 Amps
	Fuse rating	13 Amps	
	Power cable length	1.5 metres (pre-wired)	
Physical	Enclosure protection	IPX4	
	Length	349 mm	374 mm
	Width	221 mm	228 mm
	Height - excluding hoses	238 mm	
	Weight - including fittings	6.9 Kg	9.1 Kg

Stuart Turner reserve the right to amend the specification in line with its policy of continuous development of its products.

*Note: Max working pressure is the maximum pressure that can be applied to the pump internal casing under any installation conditions.

**Note: With footvalve fitted.

Although these pumps are self priming we recommend a footvalve/strainer is used if a suction lift is required.

6.11 **Noise:** The equivalent continuous A-weighted sound pressure level at a distance of 1 metre from the pump does not exceed 73 dB(A) for Jet 55-45 or 76 dB(A) for Jet 80-45.

7 TROUBLE SHOOTING GUIDE

Symptoms	Probable Cause	Recommended Action
Pump will not start.	Electrical. Pump jammed. Integral motor thermotrip activated.	Check power supply. Check fuse (see fuse section). Check circuit breaker is set. Check wiring connections. If motor 'Buzzes' switch off power and contact Stuart Turner. Wait for thermotrip to auto-reset and check that duty point and run time is within specification (see technical specification).
Reduced/intermittent flow.	Incorrect or no anti-aeration flange fitted. Incorrect pipe sizes. Blocked inlet filters. Blocked shower head spray plate.	Check that the installation complies with installation instructions. Check for correct pipe sizing, see Page 5 – Section 2.18. Clean inline strainer. Clean in accordance with manufacturers instructions.

- 7.11 **Environment Protection:** Your appliance contains valuable materials which can be recovered or recycled.
At the end of the products' useful life, please leave it at an appropriate local civic waste collection point.

8 YOUR 1 YEAR GUARANTEE

Congratulations on purchasing a Stuart Turner pump.

We are confident this pump will provide many years of trouble free service as all our products are manufactured to the very highest standard.

All Jet Pumps are guaranteed to be free from defects in materials or workmanship for 1 year from the date of purchase.

Within the guarantee period we will repair, free of charge, any defects in the pump resulting from faults in material or workmanship, repairing or exchanging the whole unit as we may reasonably decide.

Not covered by this guarantee: Damage arising from incorrect installation, improper use, unauthorised repair, normal wear and tear and defects which have a negligible effect on the value or operation of the pump.

Reasonable evidence must be supplied that the product has been purchased within the guarantee term prior to the date of claim (such as proof of purchase or the pump serial number).

This guarantee is in addition to your statutory rights as a consumer. If you are in any doubt as to these rights, please contact your local Trading Standards Department.

In the event of a claim please telephone '**TechAssist**' or return the pump and flexible hoses with the accessories removed e.g pipes etc. If you have any doubt about removing a pump, please consult a professional.

+44 (0) 800 31 969 80

Proof of purchase should accompany the returned unit to avoid delay in investigation and dealing with your claim.

You should obtain appropriate insurance cover for any loss or damage which is not covered by Stuart Turner Ltd in this provision.

Please record here for your records.

TYPE NO.	SERIAL NO.	DATE PURCHASED

NOTES

NOTES



DECLARATION OF CONFORMITY

Machinery Directive – 2006/42/EC

BS EN 12100, BS EN 809

Low Voltage Directive – 2014/35/EU

BS EN 60335-1, BS EN 60335-2-41

EMC Directive – 2014/30/EU

BS EN 55014-1, BS EN 55014-2, BS EN 61000-3-2, BS EN 61000-3-3,

BS EN 61000-4-2, BS EN 61000-4-3, BS EN 61000-4-4, BS EN 61000-4-5, BS EN 61000-4-6,

BS EN 61000-4-11

EMF Directive – 1999/519/EC

BS EN 62233

RoHs Directive – 2011/65/EU

WEEE Directive – 2012/19/EU

IT IS HEREBY CERTIFIED THAT THE STUART ELECTRIC MOTOR DRIVEN PUMP AS SERIAL NUMBER BELOW, COMPLIES WITH THE ESSENTIAL REQUIREMENTS OF THE ABOVE E.E.C. DIRECTIVES.



RESPONSIBLE PERSON
AND MANUFACTURER

STUART TURNER LIMITED
HENLEY-ON-THAMES, OXFORDSHIRE
RG9 2AD ENGLAND.

Signed  Engineering Manager

Stuart Turner are an approved company to BS EN ISO 9001:2015



Stuart Turner Ltd, Henley-on-Thames, Oxfordshire RG9 2AD ENGLAND

Tel: +44 (0) 1491 572655, Fax: +44 (0) 1491 573704

info@stuart-turner.co.uk www.stuart-turner.co.uk