

TRITON

MINI SEQUENTIAL
mixer shower
86005760

**REGISTER ONLINE
ENTER A PRIZE DRAW**

**WIN
£100**

RETAIL VOUCHERS

VISIT OUR WEBSITE TODAY

TRITONSHOWERS.CO.UK/REGISTER

*PRODUCT REGISTRATION IS ONLY AVAILABLE
TO UNITS PURCHASED & INSTALLED IN THE UK*

FOR YOUR SERVICE REFERENCE

NOTE DOWN THE PRODUCT CODE BELOW
(FROM THE LABEL ON THE FRONT OR TOP OF THE BOX)

ALTERNATIVELY REGISTER BY TEL: 024 7637 8321

Handle styles may vary
Illustrations are for guidance only

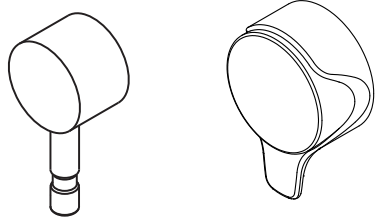
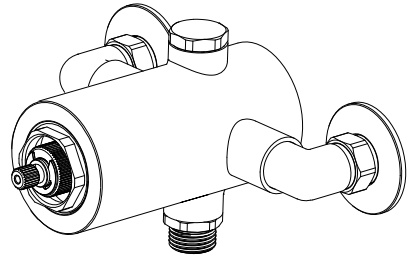

IMPORTANT SAFETY ADVICE

The shower head and hose supplied with this product are a safety critical part of your shower. Failure to use genuine Triton parts may cause injury and invalidate your guarantee.

INSTALLATION AND OPERATING INSTRUCTIONS

Please read this book thoroughly and familiarise yourself with all instructions before commencing installation and keep it for future reference.

The mixer shower installation **MUST** be carried out by a suitably qualified person, **in the sequence of this instruction book.**

Mini Exposed Sequential Thermostatic Mixer Shower

| CONTENTS | Page |
|---|-------------|
| MAIN COMPONENTS..... | 1 |
| DIMENSIONS | 2 |
| INTRODUCTION..... | 3 |
| SITE REQUIREMENTS | 3 |
| SAFETY WARNINGS | 3 |
| PRODUCT APPROVALS..... | 3 |
| PLUMBING REQUIREMENTS | 4 |
| WATER SYSTEM REQUIREMENTS..... | 4 |
| TYPICAL DOMESTIC INSTALLATIONS..... | 5 - 7 |
| INSTALLATION..... | 8 - 12 |
| FITTING THE SHOWER | 8 - 9 |
| FLOW REGULATION..... | 10 |
| LEAK TESTING | 10 |
| FITTING THE CONTROLS..... | 11 |
| OPERATING THE SHOWER | 12 |
| COMMISSIONING..... | 13 |
| ANTI-SCALD PROTECTION | 13 |
| ADJUSTING THE MAXIMUM TEMPERATURE SETTING | 14 |
| PRODUCT FLOW RATES | 15 |
| MAINTENANCE | 16 |
| CLEANING THE FILTERS | 16 |
| MODEL NAMES AND PRODUCT CODES | 17 |
| FAULT FINDING..... | 18 - 19 |
| GUARANTEE, SERVICE POLICY, etc..... | rear cover |

INSTALLERS PLEASE NOTE THESE INSTRUCTIONS ARE TO BE LEFT WITH THE USER

To check the product suitability for commercial and multiple installations, please contact Triton's specification advisory service before installation.

Telephone: 024 7637 2222

Email: technical@tritonshowers.co.uk

MAIN COMPONENTS

Valve

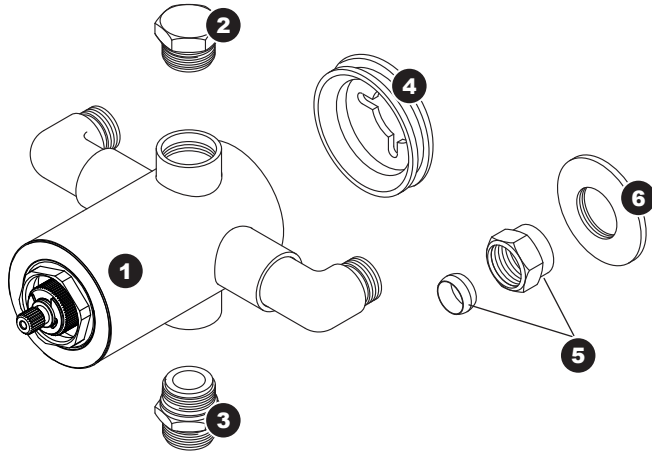

Handle Variations

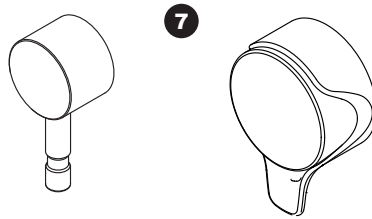

- 1. Mixer shower body
- 2. Blanking plug
- 3. Outlet adaptor
- 4. Mounting plate

- 5. Inlet nut and olive x2
- 6. Wall trim x2
- 7. Handles

Mini Exposed Sequential Thermostatic Mixer Shower

Fig.2

DIMENSIONS

All dimensions regarding the product and installation are approximate.

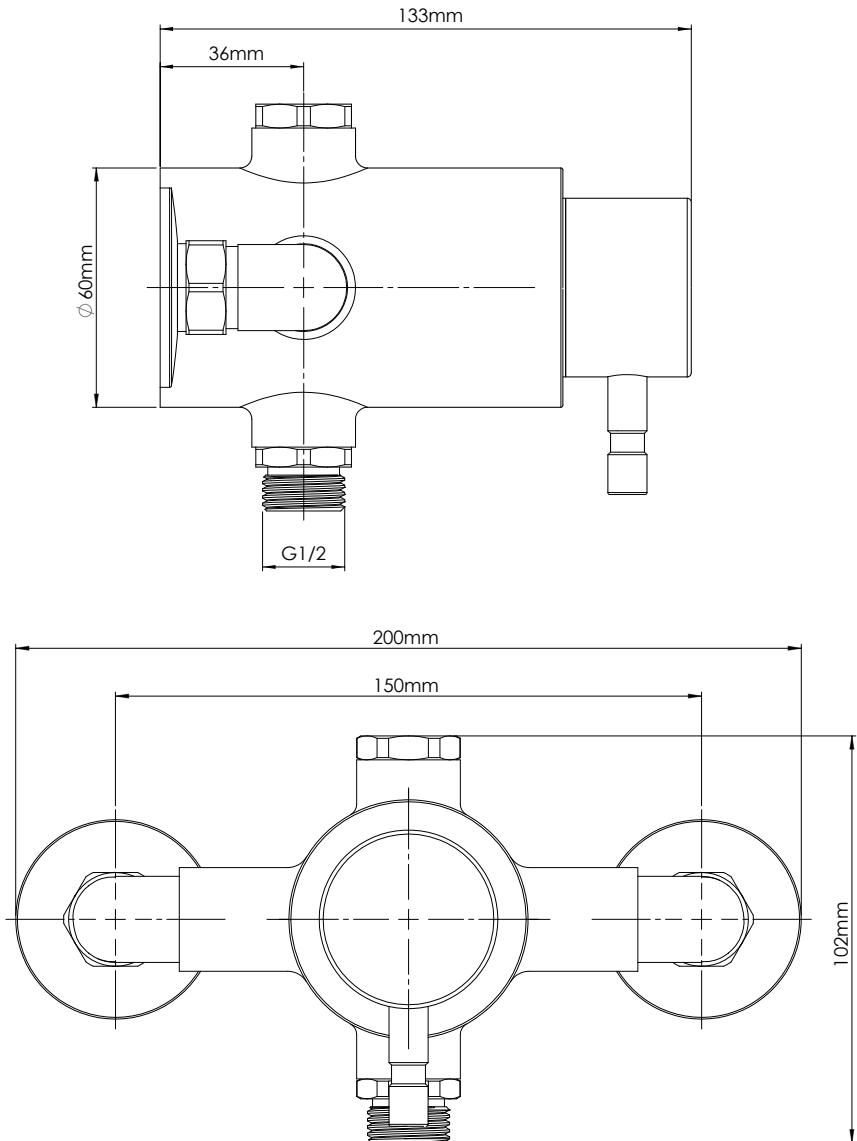

INTRODUCTION

This book contains all the necessary fitting and operating instructions for your mixer shower. Please read them carefully and read through the whole of this book before beginning your installation.

The shower installation must be carried out by a suitably competent person and in sequence of this instruction book.

Care taken during the installation will give a long and trouble free life from your mixer shower.

SITE REQUIREMENTS

The installation must be in accordance with water supply (water fittings) regulation 1999 and/or local Bylaws.

| | |
|---------------------------------|--------------------------|
| Maximum static pressure (Bar) | 10 |
| Flow pressure, hot & cold (Bar) | 0.5 to 5 |
| Hot supply temperature (°C) | 55 to 65 |
| Cold supply temperature (°C) | Equal to or less than 25 |

This mixer shower is designed for high pressure systems found in the UK, but can be installed with low pressure gravity water systems with reduced flow rates.

For effective operation of the internal seals, the maximum static pressure must not be exceeded.

A stored water temperature of 60°C is considered sufficient to meet all normal requirements and will minimise the effects of scale in hard water areas.

Valves operating outside these conditions of use cannot be guaranteed to operate as Type 2 valves.

Pressure Reducing Valve

On sites where the running pressure is above 5 bar, the use of a suitably sized pressure reducing valve fitted in the cold mains supply pipework can provide nominally equal pressures at the mixer shower.

Water Minimum Flow Rate

For best performance within the specified running pressure range a minimum flow of 8 litres per minute should be available to both inlets.

Water Temperature Adjustment and Thermal Safety

The mixed water temperature can be adjusted from cold through to a top limit which must be preset during installation with full anti-scald protection throughout the range (35°C to 40°C) providing the hot water temperature at the inlet remains 10°C above the outlet temperature.

Should there be a loss of flow to either incoming supply then water from the shower will stop or be reduced until both supplies are restored.

SAFETY WARNINGS

DO NOT allow the inlet pressure or flow rates to operate outside the guidelines laid out in Site Requirements.

DO NOT connect the mixer shower to a gravity hot supply and a mains cold supply or vice versa.

APPROVALS

This mixer valve has the following approvals

- **WRAS**

PLUMBING REQUIREMENTS

DO NOT choose a position where the shower could become frozen.

DO NOT connect to any form of tap or fitting not recommended by the manufacturer.

DO NOT use jointing compounds on any pipe fittings for the installation.

DO NOT solder fittings near the shower as heat can transfer along the pipework and damage the shower.

DO NOT subject the shower to a water temperature above 80°C during installation, use, maintenance or disinfection.

IMPORTANT:

- The layout and sizing of pipework **MUST** be such that nominally equal inlet supply pressures are achieved and the effects of other draw-offs are minimised.
- The pipework should be installed such that other taps and appliances being operated elsewhere on the premises do not significantly affect the flow
- When connecting pipework avoid using tight 90° elbows; swept or formed bends will give the best performance.
- The hot water pipe entry **MUST** be made to the left-hand side inlet, marked HOT, 'H' or with a red/orange label.
- Suitable isolating valves (complying with Water Regulations and Bylaws) **MUST** be fitted on the hot and cold water supplies to the shower as an independent means of isolating the water supplies should maintenance or servicing be necessary; position as close as is practicable to the water supply inlets of the mixer shower. If this isolator is fitted in a loft space, the loft must have a fixed access ladder and be boarded, with appropriate lighting from the access point to the isolator.
- Flush pipework to clear the system of debris and check for leaks before connecting to the mixer.

Commercial Applications

For commercial applications in-line filters are recommended.

Hard Water Areas

- a. If it is intended to operate the shower in areas of hard water (above 200-ppm temporary hardness), a scale inhibitor may have to be fitted. For advice on the scale inhibitor, please contact our Triton Customer Experience team.
- b. For best performance the showerhead **MUST** be regularly cleaned to remove scale and debris.

WATER SYSTEM REQUIREMENTS

This mixer shower is suitable for:

- Gravity water systems
- Pumped gravity systems
- Fully modulating type combination boilers
- Multi-point hot water heaters
- Thermal storage
- Unvented systems

When installing this shower with a combination or multi-point boiler, it may be necessary to install flow regulation.

Check that the appliance is capable of delivering hot water at a minimum switch-on flow rate of 3 litres per minute. At flow rates between 3 and 8 litres per minute, the appliance **MUST** be capable of raising the water temperature to 52°C minimum.

Water temperature at the inlet of the mixer valve **MUST** remain relatively constant when flow rate adjustments are made - refer to the appliance operating manual to confirm compatibility with this mixer shower.

Where thermal store systems and instantaneous gas water heaters are used, if excessive draw-off takes place, the appliance may not be able to maintain an adequate output temperature. This could result in the shower temperature becoming noticeably cooler.

Flow regulators can be fitted with high-pressure water systems to reduce flow rate and assist economy.

The hot supply temperature **MUST** remain a minimum of 10°C hotter than the required blend temperature for optimum performance.

TYPICAL DOMESTIC INSTALLATIONS

Domestic Gravity Fed Systems (fig.3)

The mixer shower **MUST** be fed from a cold water cistern and hot water cylinder providing nominally equal pressures. There must be a minimum of one metre head of water. The minimum head distance is measured from the base of the cold water cistern to top of the shower head.

If valves are gravity fed then supply pressure should be verified to ensure conditions of use are appropriate for the valve.

***Fig.3**

*Diagrammatic view – not to scale. For illustration purposes only.

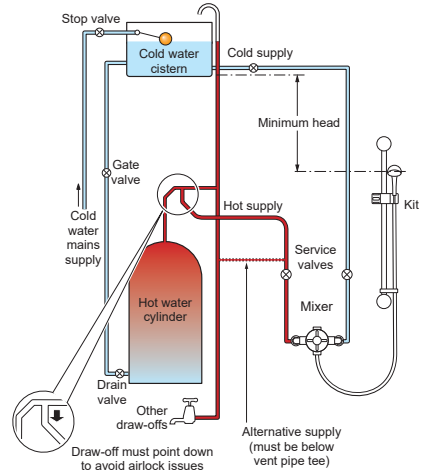

Pumped Gravity Fed Systems (fig.4)

The mixer shower **MUST** be fed from a cold water cistern and hot water cylinder providing nominally equal pressures.

The mixer shower may be used with a gravity fed system with a pump to boost pressures as shown; please refer to the pump installation guide to establish the minimum head requirements for automatic operation of the pump.

***Fig.4**

*Diagrammatic view – not to scale. For illustration purposes only.

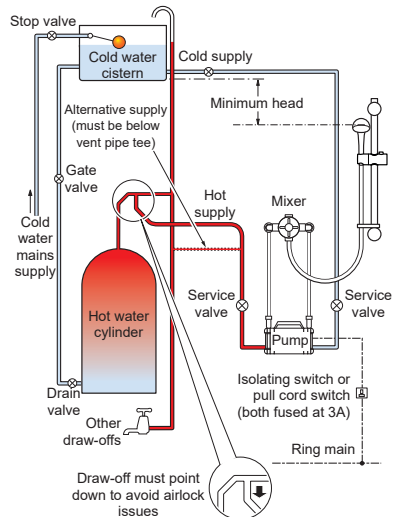

Mini Exposed Sequential Thermostatic Mixer Shower

***Fig.5**

*Diagrammatic view – not to scale.
For illustration purposes only.

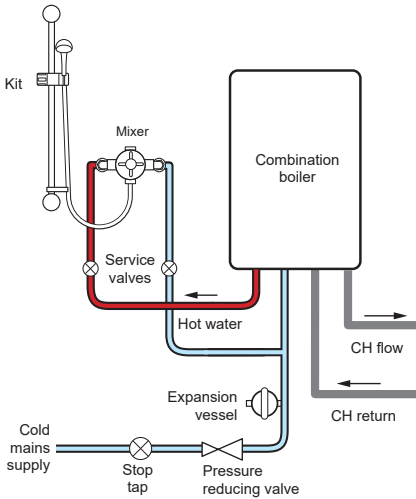

Instantaneous Gas-heated Systems, e.g. combination boilers (fig.5)

The mixer shower **MUST** be installed with a multi-point gas water heater or combination boiler of a fully modulating design i.e. to maintain relatively stable hot water temperatures.

A drop tight pressure reducing valve **MUST** be fitted if the supply pressures exceed 5 bar running.

An expansion vessel **MAY** be fitted and regularly maintained, to prevent the mixer shower being damaged by excess pressures. This may already be installed within the boiler (check with manufacturer) and is in addition to the normally larger central heating expansion vessel.

***Fig.6**

*Diagrammatic view – not to scale.
For illustration purposes only.

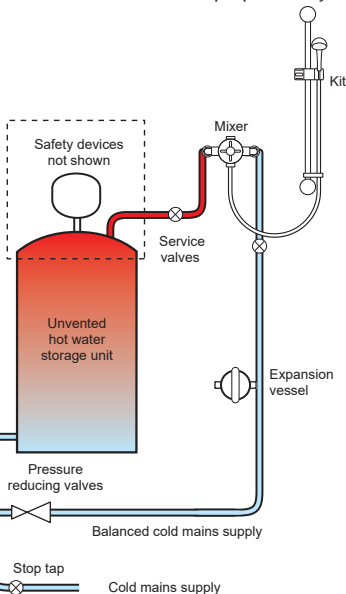

Unvented Mains Pressure Systems (fig.6)

The mixer shower can be installed with an unvented, stored hot water cylinder.

For systems with no cold water take off after the appliance reducing valve, it will be necessary to fit an additional drop tight pressure reducing valve when the mains pressure is over 5 bar. The drop tight pressure reducing valve must be set at the same value as the unvented package pressure reducing valve.

NOTE: An additional expansion vessel may be required if a second pressure reducing valve is installed. This does not apply to packages with a cold take off after the pressure reducing valve to the cylinder.

Mini Exposed Sequential Thermostatic Mixer Shower

Mains Pressurised Thermal Store Systems (fig.7)

Packages of this type, fitted with a tempering valve (blender valve) can be used. A drop tight pressure reducing valve **MUST** be fitted if the supply pressures exceed 5 bar running.

An expansion vessel **MUST** be fitted and regularly maintained, to ensure the unit is not damaged by excess pressures. This may already be installed externally or internally within the thermal store (check with thermal store manufacturer).

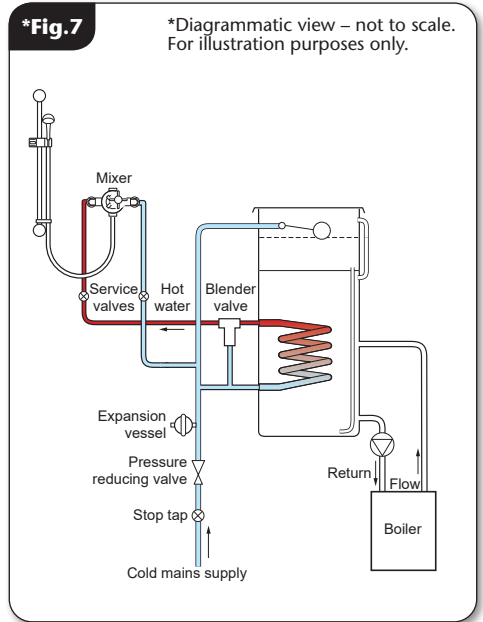

Mini Exposed Sequential Thermostatic Mixer Shower

***Fig.8**

*Diagrammatic view – not to scale.
For illustration purposes only.

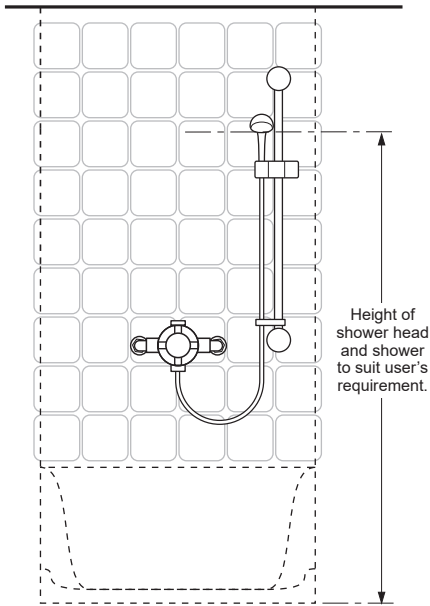

INSTALLATION

Preparing the Shower

Check the contents to make sure all parts are present.

Before starting the installation, ensure all the openings on the shower are carefully covered to stop ingress of any debris, etc. while routing the supply pipework.

The mixer shower can be installed in the following applications:

- a solid wall
- a stud partition wall
- dry lined wall
- or fixing to a shower cubicle or panel

Siting of the Shower and Accessories

Refer to **fig.8** for correct siting of the shower.

The shower should be positioned as detailed, with all controls within comfortable reach of the user.

The accessories (shower head, riser rail and/or fixed shower head) can be positioned above or to either side of the shower (**fig.8**).

The valve must be installed in a position that allows for easy access for future maintenance and commissioning.

Fig.9

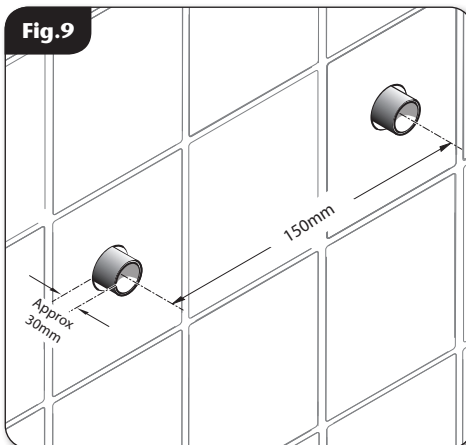

FITTING THE SHOWER

Supply Pipework

Having decided on the position of the shower and direction of pipe entry, for example rising, falling or rear entry, complete the pipework to the shower area.

The hot and cold water pipes should not be permanently attached to the wall within one metre of the mixer shower before installation is complete, to allow for final adjustment of the valve position.

For rear entry supplies, use a spirit level to mark the route of incoming hot and cold water supply pipes at a distance of 150mm between centres (**fig.9**).

Mini Exposed Sequential Thermostatic Mixer Shower

WARNING!

Check there are no hidden cables or pipes before drilling holes for wall plugs. Use great care when using power tools near water. The use of a residual current device (RCD) is always recommended.

Mark the position of the four locating screws for the mounting plate, although if installing on to a solid brick wall using two diagonal holes will usually be enough.

Drill and plug the wall. An appropriate drill bit should be used. If the wall is brick, plasterboard or a soft building block, appropriate wall plugs and screws should be fitted.

Fit the mounting plate on to the wall (fig.10).

IMPORTANT: Make sure that all supply pipework has been flushed through before fitting the mixer shower (fig.11).

The inlet elbows allow for either rising, falling or rear entry hot and cold water supplies. The elbows have 'O' ring seals (fig.12) to the body and do not require PTFE tape or other means of sealing.

Fit the trim onto the inlet water pipes followed by the nut and olive. Connect the hot water supply to the inlet marked HOT, 'H' or red/orange label and connect the cold water supply to the inlet marked COLD, 'C' or blue label (fig.13).

Tighten all compression fittings.

Tighten all the grub screws to secure the mixer to mounting plate.

The outlet adaptor and plug can be repositioned dependant on whether top or bottom outlet is required. The adaptor is suitable for a 15mm rigid pipe connection.

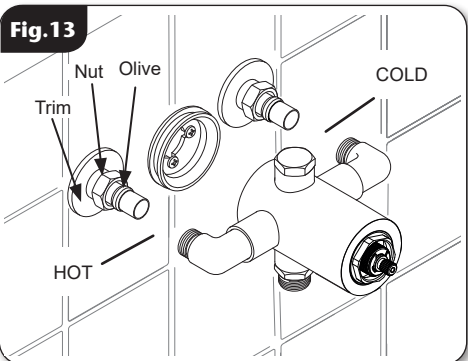
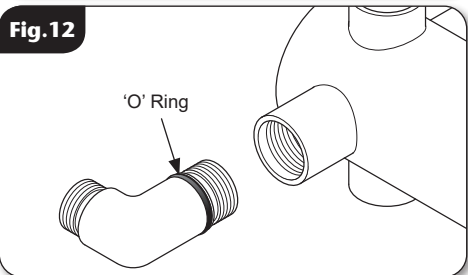
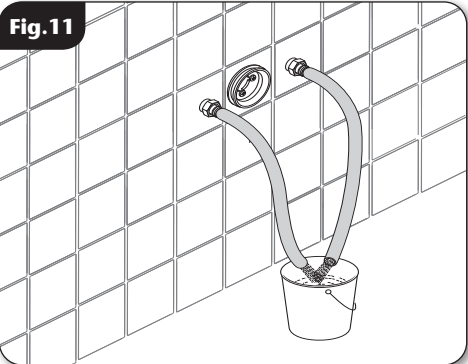
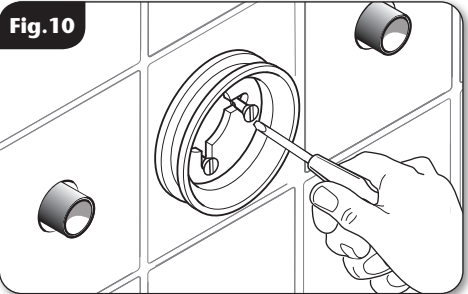
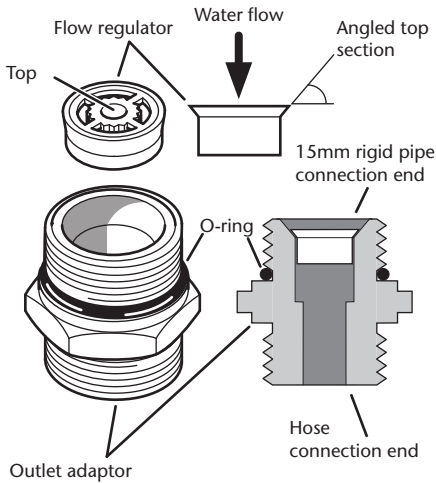

Fig. 14



Flow Regulation

A flow regulator (not supplied) is used with high-pressure water systems and may be fitted with any of the water systems listed in the Water System Requirements section to reduce flow rate and assist economy.

To fit a flow regulator (flexible hose connection) unscrew the outlet adaptor. Place the flow regulator into the rigid pipe connection end; please note the flow regulator is only designed to work in one direction (**fig. 14**).

The flow regulator for 15mm rigid pipe must be fitted into the shower head.

LEAK TESTING

Direct the outlet of the mixer to waste. Open the isolating valves to the shower and check for leaks. Remedy any leaks found.

FITTING THE CONTROLS

Fit the temperature control knob as shown in **fig.15**.

Ensure the maximum temperature stop pin is as close to the flat edge of the maximum temperature stop as possible.

Secure the knob in place with the retaining grub screw.

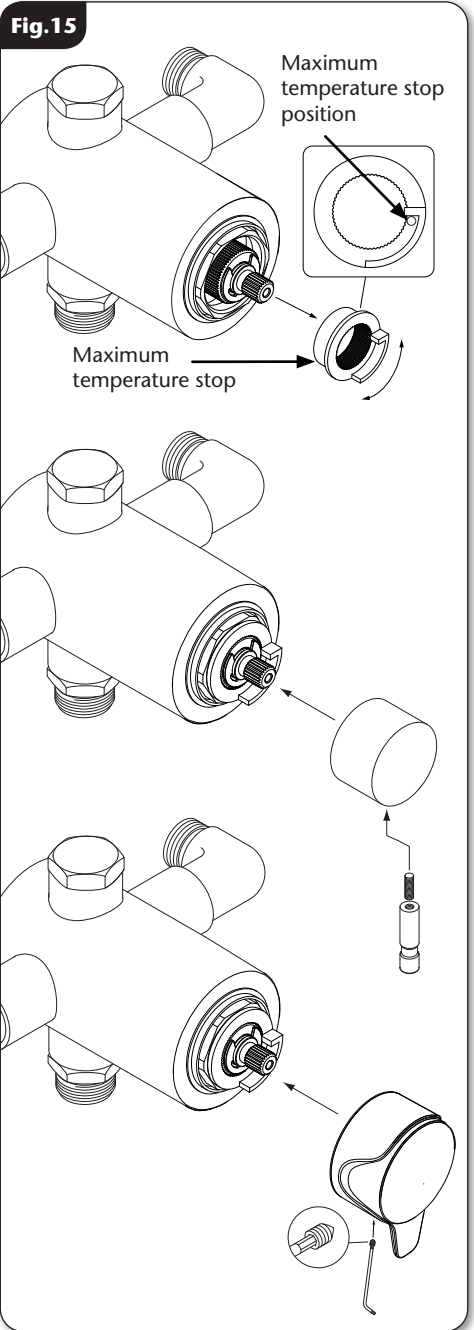
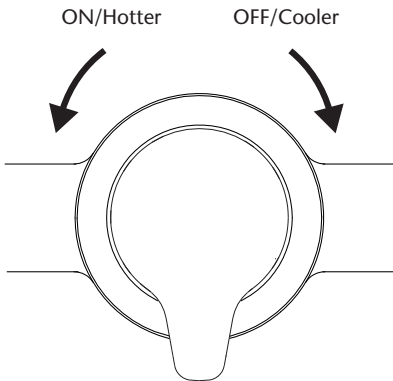
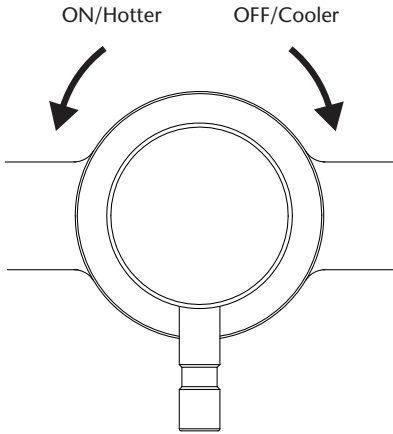

Fig. 16



OPERATING THE SHOWER

To start the shower, turn the on/off temperature control anti-clockwise (**fig. 16**).

To adjust the showering temperature rotate the temperature control clockwise for cooler and anti-clockwise for hotter.

CAUTION: Exposed metal surfaces may become hot during use.

COMMISSIONING

NOTE: The maximum temperature should be checked on site to guarantee user safety.

After fitting the controls, start the water flow by rotating the control knob.

Make sure that both the hot and cold water supplies are fully open and at (or near to) their design temperature and pressures and are within the requirements as stated in the Site Requirements section.

Make sure the temperature control is at the maximum temperature setting - rotated fully anti-clockwise.

Allow the shower to run at the maximum temperature setting until the water temperature has stabilised. Rotate the temperature control until your desired maximum showering temperature is reached.

The mixer has a temperature stop to prevent accidental rotation to higher temperatures. This is adjustable to provide a maximum temperature of 35°C – 40°C and should be checked on site to guarantee user safety.

The following is recommended for domestic installations but must be carried out for commercial installations: Check the thermal shut off facility of the mixer shower by performing a thermal shut off test.

Shut off the cold supply. The flow from the mixer shower should stop immediately or reduce to a trickle in which case the water temperature should be less than 43°C.

In either case there is no risk of scalding.

If, however, the temperature is above 43°C then it is likely there is contamination in the mixer shower stopping it from shutting off the hot supply. In this case refer to the maintenance section or contact Triton Customer Experience.

ANTI-SCALD PROTECTION

It is important that the mixer shower is tested regularly to prevent the risk of scalding and guarantee user safety. This can be carried out as follows: with the mixer blend temperature set at 38°C isolate the cold water supply. The outlet flow rate will reduce to a safe level.

Fig.17

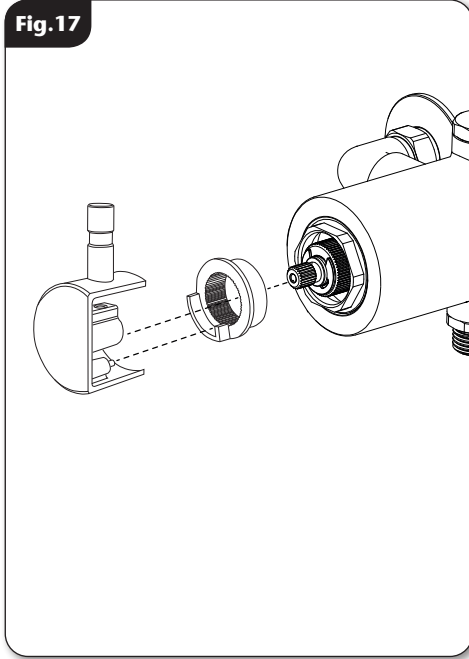

ADJUSTING THE MAXIMUM TEMPERATURE SETTING

The maximum temperature stop is factory set to 38°C, this can be adjusted during installation.

Note: Before fitting the levers the maximum temperature should be checked on site to guarantee user safety.

The BuildCert TMV scheme recommends the following set maximum mixed water outlet temperatures for use in all premises:

44°C - for bath fill but see notes below.

41°C - for showers.

41°C - for washbasins.

38°C - for bidets.

The mixed water temperatures must never exceed **46°C** at terminal fitting.

The British Burns Association recommends **37°** to **37.5°C** as a comfortable bathing temperature for children. In premises covered by the Care Standards Act 2000, the maximum mixed water outlet temperature is **43°C**.

To adjust the maximum temperature setting, remove the temperature control knob.

Allow the water to run until the temperature has stabilised, adjust the temperature control spindle by hand (**fig.17**).

When the showering temperature is satisfactory turn off the shower.

Mini Exposed Sequential Thermostatic Mixer Shower

PRODUCT FLOW RATES - For guidance only

| | | | | | | | | | | |
|-----------------|-----|-----|-----|------|------|------|------|------|------|------|
| Flow Rate (l/m) | 6.2 | 7.8 | 9.5 | 10.8 | 12.0 | 16.5 | 23.0 | 28.0 | 32.0 | 37.0 |
| Pressure (bar) | 0.1 | 0.2 | 0.3 | 0.4 | 0.5 | 1.0 | 2.0 | 3.0 | 4.0 | 5.0 |

Conditions for test

Inlet temperatures comply with EN1111 requirements.

Outlet Temperatures 38°C.

Flow Control open.

Open outlet - No hose or shower head connected.

MAINTENANCE

The following maintenance procedure must be carried out for commercial and health care premises, but is not necessarily required for domestic installations.

Maintenance of the shower is required to give continued performance after installation and so that it continues to provide scald prevention.

Note: A thermostatic mixing valve in need of maintenance can be undetectable in normal use and only becomes apparent when a disruption occurs in the hot or cold water supply temperatures or pressures.

The frequency of routine maintenance of the internal of the valve will depend mainly on the water supply condition. Experience of local conditions will dictate the intervals for inspection and in-service testing; guidance has been given below which can be adjusted for local requirements.

- a) Initially check the filters for debris once every three months and clean if necessary.
- b) Perform a thermal shut off test every three months, and check the maximum temperature setting. See the Commissioning section for the details of this test and readjustment of the maximum temperature setting if required.
- c) If the maximum water temperature varies by more than 2°C from the commissioned setting then carry out the following checks
 - Check the isolating valves are fully open.
 - Check the internal surface for scaling.

If the body requires descaling then it should be removed from the pipework to carry out this work - all rubber parts must be removed before descaling.

- Check the function of the non-return valves

NOTE: The non-return valves (NRVs) prevent cross-flow between hot and cold supplies under unequal pressure conditions. They are designed for long life with no maintenance.

If these checks do not highlight the reason for the temperature variation, then internal components will require replacement - please see Customer Experience contact details.

Cleaning

We recommend that all products are cleaned using warm, soapy water and dried with a suitable cloth to help prevent limescale from forming. Regularly drying your product after use will help prevent limescale build-up and watermarks.

Do not use abrasive or aggressive chemical cleaning products as this may affect the product surface finish and invalidate your guarantee.

Cleaning the Filters (fig.A)

It is advised that this should be carried out by a qualified person.

- Turn off the water supplies before starting.
- To gain access to the filters remove the unit from the inlet fittings.
- Remove hot and cold elbows.
- Remove the retaining clip and NRV.
- Wash the filter thoroughly under running water, use a suitable brush to remove all debris.
- Reassemble the shower.

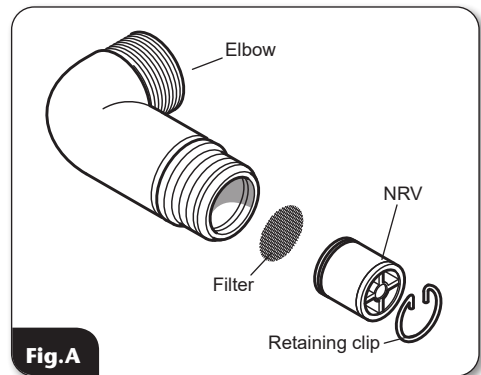

Fig.A

Disinfection

Where chlorine is used for the disinfection of water systems all relevant guidelines and approved codes of practice must be strictly followed. Failure to comply with the relevant guidelines and approved codes of practice may invalidate your guarantee.

Mini Exposed Sequential Thermostatic Mixer Shower

MODEL NAME

ASANA
DENE
MOYA
PREMA

PRODUCT CODE

SFXASATHSM
UNDETHEXSQM
HMMOYTHSMNFH
TOLPRETHSM

Mini Exposed Sequential Thermostatic Mixer Shower

FAULT FINDING

The following can be carried out by a competent person

| Problem | Cause | Action |
|--|---|---|
| 1 Water too hot. | 1.1 Temperature control incorrectly commissioned. | 1.1.1 Refer to the Commissioning section. |
| | 1.2 Not enough cold water flowing through shower. | 1.2.1 Reposition the temperature control. |
| | 1.3 Increase in the ambient cold water temperature. | 1.3.1 Reposition the temperature control. |
| | 1.4 Cold water supply blocked. | 1.4.1 Turn off shower and consult a competent plumber or contact Triton Customer Experience. |
| | 1.5 High volume of cold water drawn off elsewhere. | 1.5.1 Reduce the simultaneous demand from the mains supply. |
| 2 Water too cold. | 2.1 Temperature control incorrectly commissioned. | 2.1.1 Refer to the Commissioning section. |
| | 2.2 Not enough hot water flowing through shower. | 2.2.1 Reposition the temperature control. |
| | 2.3 Decrease in the ambient cold water temperature. | 2.3.1 Reposition the temperature control. |
| | 2.4 Insufficient hot water supplies from the heating system. | 2.4.1 Make sure heating appliance is set to maximum or has sufficient stored hot water. |
| | | 2.4.2 Make sure heating appliance is igniting by trying a hot water tap elsewhere. |
| 2.5 Hot water supply blocked or restricted. | 2.5.1 Turn off shower and consult a competent plumber or contact Triton Customer Experience. | |
| 3 High water flow and/ or poor performance on a mains fed system. | 3.1 Flow regulators not fitted. | 3.1.1 Fit a suitable flow regulator (see Flow Regulation section). |

Mini Exposed Sequential Thermostatic Mixer Shower

FAULT FINDING

| Problem | Cause | Action |
|--|--|---|
| 4 Water does not flow or shower pattern collapses when another outlet is turned on. | 4.1 Water supplies cut off. | 4.1.1 Check water elsewhere in house and if necessary contact local water company. |
| | 4.2 Shower unit blocked. | 4.2.1 Inspect the filters. Clean if necessary. |
| | 4.3 Blockage in pipework. | 4.3.1 Turn off the shower and consult a suitably competent plumber. |
| | 4.4 Shower head blocked. | 4.4.1 Clean the shower head. |
| | 4.5 System not capable of supplying multiple outlets at the same time. | 4.5.1 Make sure stop or service valve is fully open. |
| 4.5.2 Check if there is sufficient water pressure. | | |
| The following is recommended for a professional qualified installer only | | |
| 5 Water too cold. | 5.1 Running pressure is excess of maximum recommended. | 5.1.1 Fit a pressure reducing valve. |
| 6 Shower controls noisy when in use. | 6.1 Running pressure in excess of maximum recommended. | 6.1.1 Fit a pressure reducing valve. |
| 7 Shower will not shut off. | 7.1. Pipework not flushed out before connecting to the unit. Internal components damaged. | 7.1.1 Service valve. |

UK SERVICE POLICY

In the event of a product fault or complaint occurring, the following procedure should be followed:

DO NOT REMOVE THE PRODUCT

1. Telephone Customer Experience on **024 7637 2222** having available your details including post code, the model number and power rating of the product, together with the date of purchase and, where applicable, details of the particular fault.
2. If required, the Customer Experience Advisor will arrange for a qualified engineer to call.
3. All products attended to by a Triton service engineer must be installed in full accordance with the Triton installation guide applicable to the product; this can be downloaded free at www.tritonshowers.co.uk/guides.
4. Our engineer will require local parking and if a permit is required, this must be available to the engineer on arrival at the call.
5. If loft access is required for isolation or to complete a repair, the loft must have a fixed access ladder and be boarded, with appropriate lighting from the access point to and around the repair area.
6. It is essential that you or an appointed representative (who must be over 18 years of age) is present for the duration of the service engineer's visit. If the product is in guarantee you must produce proof of purchase.
7. Where a call under the terms of guarantee has been booked and the failure is not product related (i.e. scaling and furring, incorrect water pressure, pressure relief device operation or electrical/plumbing installation fault) a charge will be made. A charge will also be issued if nobody is at the property when the service engineer calls or adequate parking/permit is not available.
8. If the product is no longer covered by the guarantee an up-front fixed fee will be charged before the site visit.
9. Your receipt must be retained as proof of purchase. Should proof of purchase not be available on an 'in-guarantee' call, or should the service engineer find that the product is no longer under guarantee, the engineer will charge the same fixed price and will request payment prior to departing. If payment is not made on the day an administration charge will be added to the fixed charge.
10. If a debt is outstanding from a previous visit, or from any other Triton purchase, Triton reserves the right to withhold service until the debt has been settled.
11. Triton takes the health, safety and wellbeing of its employees very seriously and expects customers to treat all staff members with respect. Should any employee feel threatened or receive abuse, either verbally or physically, Triton reserves the right to withhold service.

Replacement Parts Policy

In line with AMDEA guidelines, Triton retains functional spares for as long as there is a market for them and in most cases, well beyond. Due to the vast array of product types, the life cycle of products can vary and therefore so can the length of time parts can be supplied. Spare parts can be ordered via our online spare parts store or by telephoning our Triton Customer Experience team on **024 7637 2222**. Payment should be made by credit / debit card (excluding American Express or Diners Card). Payment can also be made by pre-payment of a pro-forma invoice, by cheque or postal order.

Telephone orders are based on information given during the call. Before contacting Triton, please verify your requirements using the information contained in the user guide. Triton cannot accept liability for incorrect part identification.

Triton Showers
Triton Road
Nuneaton
Warwickshire, CV11 4NR

Triton is a division of Norcross Group (Holdings) Limited

Triton reserve the right to change product specification without prior notice. E&OE. © TRITON SHOWERS 2024

TRITON UK STANDARD GUARANTEE

This guarantee applies only to products installed within the United Kingdom and does not apply to products used expressly for commercial gain, unless this use has been specified by Triton. This guarantee does not affect your statutory rights.

With the exception of accessories, Triton guarantee the product against all manufacturing defects for a period of **5 years** for use in a domestic environment from the date of purchase, provided that it has been installed by a competent person in full accordance with the fitting instructions.

All accessories such as shower heads, hoses and riser rails carry a **1 year** parts only guarantee against manufacturing defects.

Any part found to be defective during this guarantee period we undertake to repair or replace at our option without charge, so long as it has been properly maintained and operated in accordance with the instructions and has not been subject to misuse or damage or the effects of limescale build up. This product must not be taken apart, modified or repaired except by a person authorised by Triton.

What is not covered:

1. Breakdown due to:
 - a) use other than domestic use by the property occupants;
 - b) wilful act or neglect;
 - c) any malfunction resulting from the incorrect use or quality of electricity, gas or water or incorrect setting of controls;
 - d) failure to install in accordance with this installation guide.
2. Claims for missing parts once the product has been installed.
3. Repair costs for damage caused by foreign objects or substances.
4. Total loss of the product due to non-availability of parts.
5. Compensation for loss of use of the product or consequential loss of any kind.
6. Call out charges due to an abortive visit or where no fault has been found with the appliance.
7. The cost of repair or replacement of isolating switches, electrical cable, fuses and/or circuit breakers or any other accessories installed at the same time. Replacement of a Pressure Relief Device that only activates when the shower outlet is blocked is also excluded.
8. The cost of routine maintenance, adjustments, overhaul modifications or loss or damage arising therefrom, including the cost of repairing damage, breakdown, malfunction caused by corrosion, furring, frost or exposure to freezing conditions.
9. Call out charges where the water supply cannot be isolated, this includes consequential losses arising from unserviceable supply valves, or inaccessible product or valves located in a loft space without suitable access.

For the latest Terms & Conditions please see:

www.tritonshowers.co.uk/terms

PLEASE NOTE PRODUCT REGISTRATION IS ONLY AVAILABLE TO UNITS PURCHASED & INSTALLED IN THE UK

Customer Experience: **024 7637 2222**

Trade Installer Hotline: **024 7637 8344**

www.tritonshowers.co.uk

E-mail: CXsupport@tritonshowers.co.uk

E-mail: technical@tritonshowers.co.uk